

**Tai lift**  
*Worldwide*

**3,000 to 3,500 lb  
Gas & LPG Powered  
Pneumatic tire lift trucks**

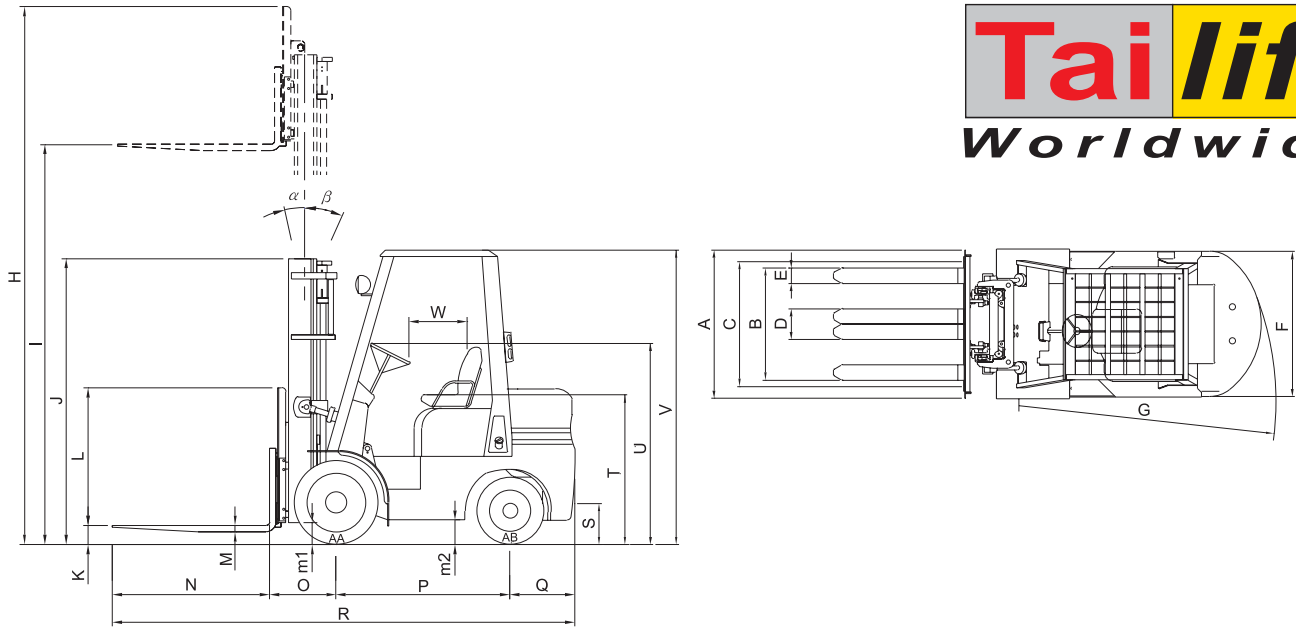

**CE ISO 9001**



## DIMENSIONS

Item	Model	FG15P	FG18P
Capacity	lbs	3000	3500
Load center	in	24	24
Overall width	A	41.9	41.9
Outside width between forks	B	36.2	36.2
Front wheels tread	C	34.8	34.8
Width of two forks	D	7.9	7.9
Width of one fork	E	3.9	3.9
Rear wheels tread	F	35.4	35.4
Min. turning radius. Outside	G	76.8	78.5
Max height overall	H	166	166
Max. fork height	I	118	118
Height of mast	J	78.7	78.7
Free lift	K	0.0	0.0
Height of load backrest	L	48	48
Max. thickness of fork	M	1.4	1.4
Length of fork	N	42	42
Distance between front and center of wheel	O	16.7	16.7
Wheel Base	P	53.1	53.9
Distance between front and center of rear wheel	Q	18.1	19.4
Overall length	R	130.1	132.3
Ground At lowest point	m1	4.7	4.7
Clearance Center of wheelbase	m2	7.1	7.1
Height of tail	S	10.3	10.3
Seat height	T	42.9	42.9
Height of steering wheel	U	57.3	57.3
Height of overhead guard	V	81.5	81.5
Space of driver's seat	W	16.5~23.6	
Dimension of front wheel	AA	6.50-10-10 P.R.	
Dimension of rear wheel	AB	5.0-8-80 P.R.	

## MAIN SPECIFICATIONS

Item	Model	FG FG15P	FG FG18P
Load (lbs)		3000	3500
Load Center (in.)		24	24
Mast tilting range (deg)	Front	6°	6°
	Rear	6°	6°
Lifting speed (in / sec)	No load	22.4"	22.4"
	Full load	20.8"	20.5"
Lowering speed (in/ sec)	No load	17.3"	17.3"
	Full load	17.7"	17.7"
Travel speed (mph)	No load	10	10
	Full load	10.6	10.6
Gradeability (deg)	No load	11.3	11.3
	Full load	14.5	14.5
Fuel tank capacity (gallon)		12.4	12.4
Oil tank capacity		12.4	12.4
Net weight (lbs)		6530	6750
Max. drawbar pull (lbs)		3124	3190

### Standard features include:

Automatic transmission with trans cooler, 3rd valve and handle, high air intake, class II carriage with six roller bearings, headlight, rear back-up light, and turn signals

### Engine Options

LPG:	GM	3.0L	75HP
Diesel	Isuzu	4JG2-PJ03	61.6HP

Specifications are subject to improvements and changes without notice.

**Authorized distributor:**